

GUHRING

LT 800 WP

The economical
insert drilling system

- for deep and large holes
- from 40 to 100 mm diameter
- for drilling depths up to $12 \times D$



The front cover shows a 50 mm LT 800 tool drilling a blind hole in a gas compressor shaft of 900 mm diameter (drilling depth 270 mm, 6 x D).

Contents

Page

System summary \varnothing 40...< 60 mm	2
System summary \varnothing 60...100 mm.....	4
Overview of inserts and drill head arrangements	6
Program selection with drilling depth spectrum	8

Program

Basic adaptors, HSK reductions, HSK extensions	10
HSK holders and extensions.....	12
Drill heads and accessories	14
Cartridges and accessories.....	16
Interchangeable inserts and accessories.....	18

General technical parameters

Assembly instructions (size 400...560).....	20
Assembly instructions (size 600...950).....	21
Coolant pressure and volume.....	22
Recommended values for the machining of steel	22
Performance comparison	23
Guhring guide/application recommendations.....	24



LT 800 WP drilling system (\varnothing 40...100 mm)

Until recently, the economical production of deep and especially large holes above 40 mm diameter with carbide tools was only achievable with the assistance of costly special solutions. The successful development LT 800 WP now provides a modular and therefore cost-effective solution for this difficult area of machining. This amazingly for up to 100 mm diameter and a drilling depth up to 12 x D!

The holder is equipped with coolant ducts, the interchangeable inserts are produced in ultra fine grade carbide. Further, important advantages:

Optimal adaptability to every machining task due to the combination possibilities of different tool holders (i.e. HSK, ISO taper, VDI) with extensions, reductions and drill heads with interchangeable inserts.

Powerful 'double cutting edge' thanks to lightly modified LTT ISO indexable inserts with circular lands positioned in pairs.

Simple replacement of the drill head and the interchangeable insert.

Accurate spotting provided by interchangeable insert with special Ratio point geometry.

Good support through the complete drilling depth thanks to double-sided lands.

Last but not least: LT 800 WP is ideally suited as a core drill for the enlarging of drilled holes. Also remarkable is the fact that, depending on diameter and material, holes up to 12 x D can be produced, i.e. gun drilling.



LT 800 · System Summary · \varnothing 40...< 60 mm

Basic adaptors

ISO taper basic adaptors

• Guhring no. ...code no.

4512

Basic adaptors (VDI)

4510

HSK tool holder modules

Reductions

4355

Extensions

4549

Holder size (Ø-range)	Nom.-* Ø adjustable	Basic adaptors (VDI) 4510	Reductions 4355	Extensions 4549
400 (40...42.9)	40.0			
	41.0			
	42.0			
430 (43...45.9)	43.0			
	44.0			
	45.0			
460 (46...48.9)	46.0			
	47.0			
	48.0			
490 (49...51.9)	49.0			
	50.0			
	51.0			
520 (52...55.9)	52.0			
	53.0			
	54.0			
560 (56...59.9)	55.0			
	56.0			
	57.0			
	58.0			
	59.0			

• Guhring no. always together with code no.!

* for intermediate-Ø please consult Guhring application technician.

The last column for the respective holder size indicates the max. nom.-Ø.

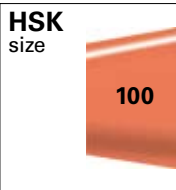
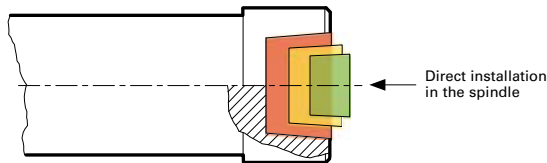

HSK holders

15° spiral

Extensions

3 x D
15° spiral

Drill heads

1 x D

Cartridges

for mounting external indexable inserts (x 2 per drill head)*

4142

4148

4150

4160

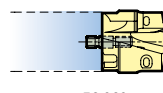
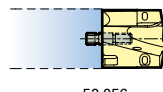
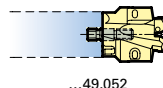
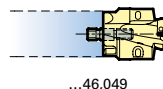
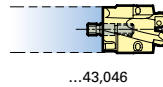
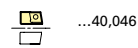
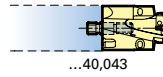
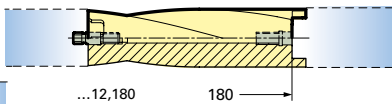
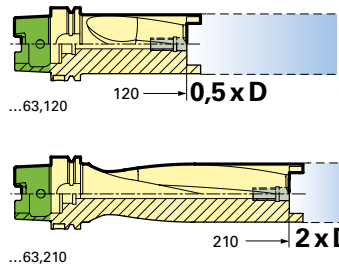
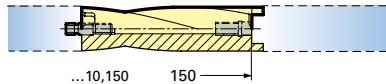
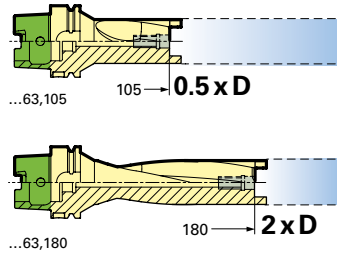

Nom.-
Ø
adjustable

Holder
size
(Ø-range)

40.0	400
41.0	
42.0	
43.0	430
44.0	
45.0	
46.0	460
47.0	
48.0	
49.0	490
50.0	
51.0	
52.0	520
53.0	
54.0	
55.0	560
56.0	
57.0	
58.0	
59.0	

* for cartridge arrangement see page 19

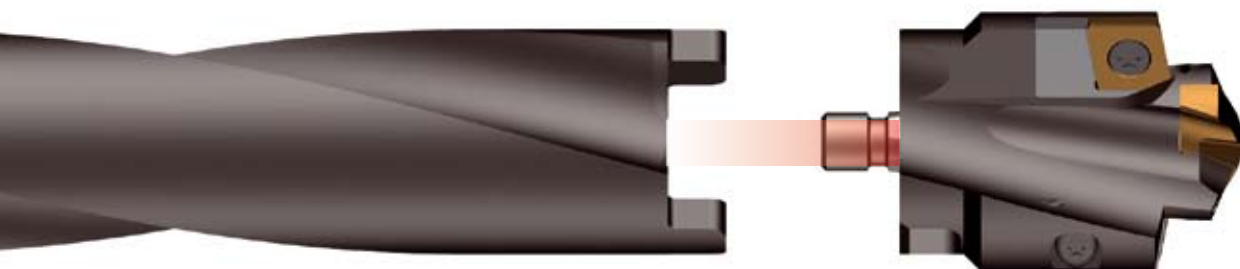
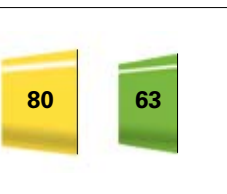

LT 800 · System Summary · Ø 60...100 mm

Basic adaptors

ISO taper basic adaptors

• Guhring no. **4512**
...code no.

HSK tool holder modules

Reductions

4355

Extensions

4549

Basic adaptors (VDI)

4510

Holder size (Ø-range)	Nom.-* Ø adjustable	Basic adaptors (VDI) 4510	Reductions 4355	Extensions 4549
600 (60...64.9)	60.0			
	61.0			
	62.0			
	63.0			
650 (65...69.9)	64.0			
	65.0			
	66.0			
	67.0			
700 (70...74.9)	68.0			
	69.0			
	70.0			
	71.0			
750 (75...79.9)	72.0			
	73.0			
	74.0			
	75.0			
800 (80...84.9)	76.0			
	77.0			
	78.0			
	79.0			
850 (85...89.9)	80.0			
	81.0			
	82.0			
	83.0			
900 (90...94.9)	84.0			
	85.0			
	86.0			
	87.0			
950 (95...100)	88.0			
	89.0			
	90.0			
	91.0			
950 (95...100)	92.0			
	93.0			
	94.0			
	95.0			
950 (95...100)	96.0			
	97.0			
	98.0			
	99.0			
950 (95...100)	100.0			

• Guhring no. always together with code no.!

* for intermediate-Ø please consult Guhring application technician.
The last column for the respective holder size indicates the max. nom.-Ø.

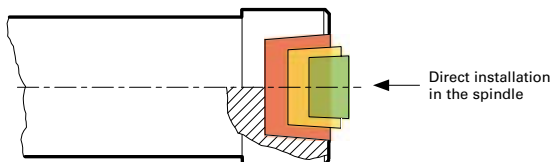

HSK size

100

HSK holders

straight, stepped design, w/o chip chamber

4144

Extensions 3 x D

straight, stepped design, w/o chip chamber











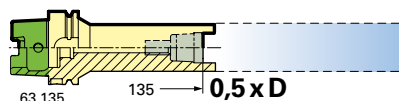
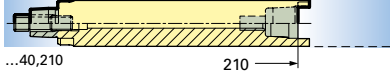
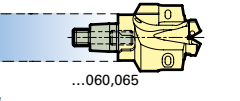

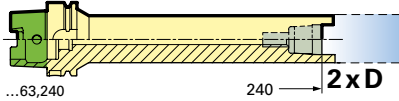

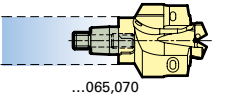

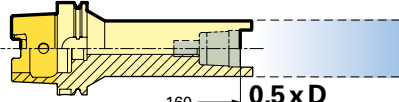
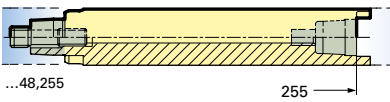
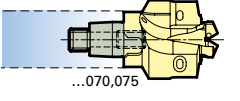

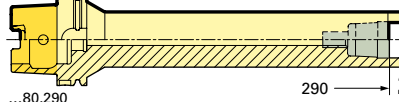
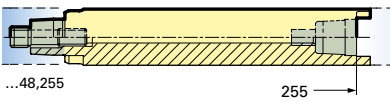
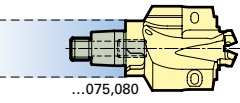

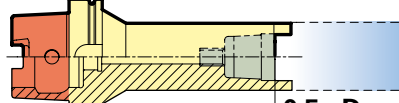
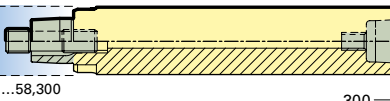
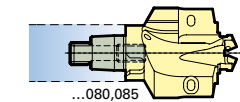

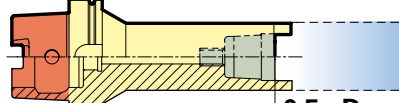
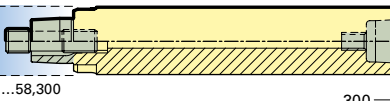
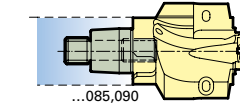

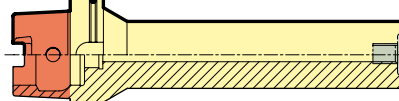
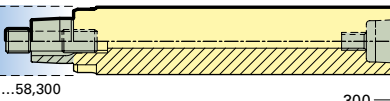
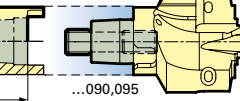

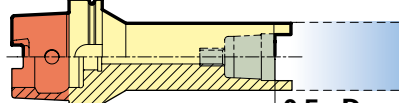
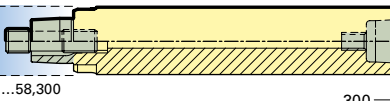
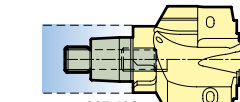

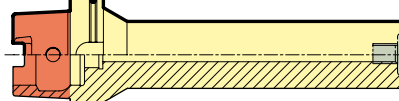
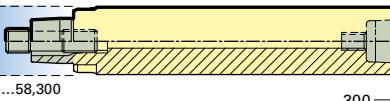
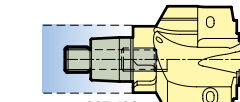

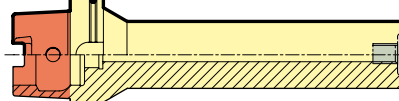
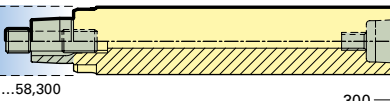
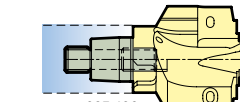

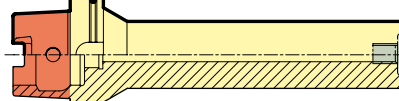
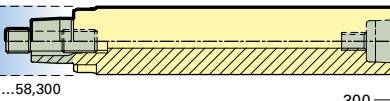
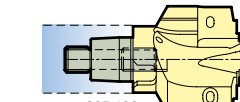

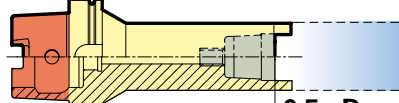
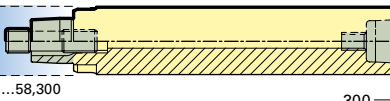
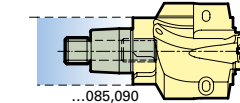

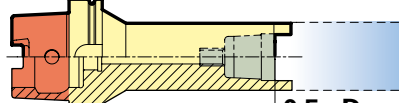
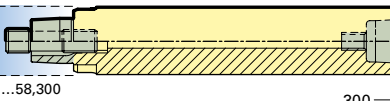
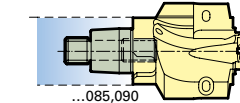

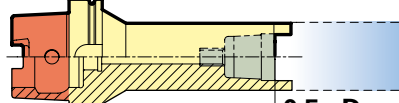
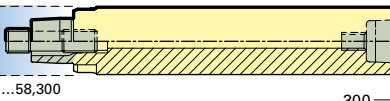
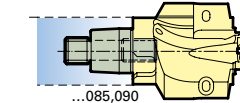

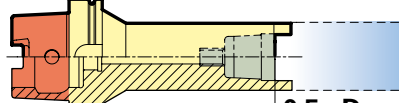
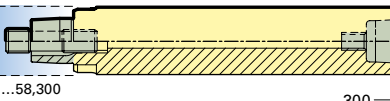
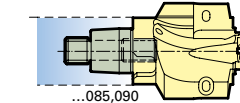

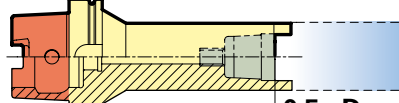
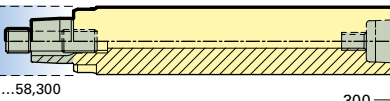
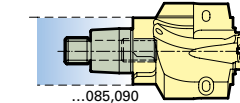

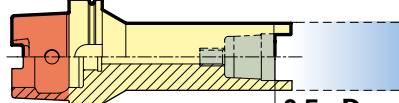
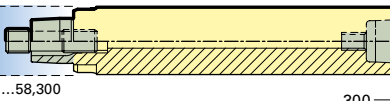
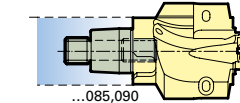
4149

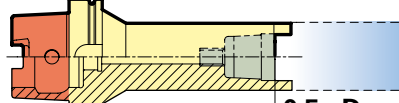
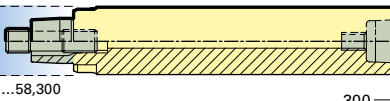
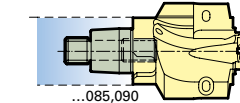
Drill heads 1 x D

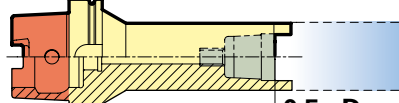
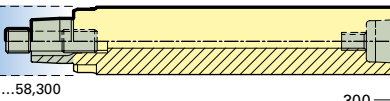
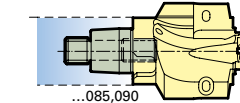
4150

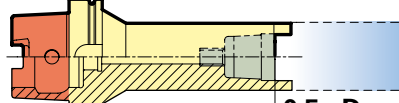
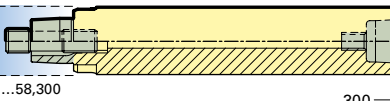
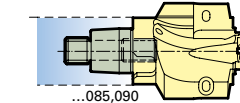
Cartridges for mounting external indexable inserts (x 2 per drill head)*

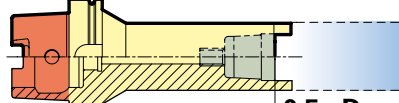
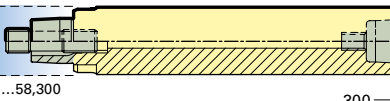
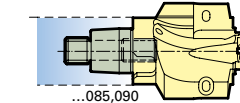
4160

						Nom.- Ø adjustable	Holder size (Ø-range)
 <p>...63,135 135 → 0,5xD</p>	 <p>...40,210 210 →</p>	 <p>...060,065</p>	 <p>...56,065</p>		60.0	600	
					61.0		
 <p>...63,240 240 → 2xD</p>	 <p>...40,210 210 →</p>	 <p>...065,070</p>	 <p>...65,070</p>		62.0		650
					63.0		
 <p>...80,160 160 → 0,5xD</p>	 <p>...48,255 255 →</p>	 <p>...070,075</p>	 <p>...70,075</p>		64.0	700	
					65.0		
 <p>...80,290 290 → 2xD</p>	 <p>...48,255 255 →</p>	 <p>...075,080</p>	 <p>...75,080</p>		66.0		750
					67.0		
 <p>...100,180 180 → 0,5xD</p>	 <p>...58,300 300 →</p>	 <p>...080,085</p>	 <p>...80,090</p>		68.0	800	
					69.0		
 <p>...100,180 180 → 0,5xD</p>	 <p>...58,300 300 →</p>	 <p>...085,090</p>	 <p>...80,090</p>		70.0		850
					71.0		
 <p>...100,330 330 → 2xD</p>	 <p>...58,300 300 →</p>	 <p>...090,095</p>	 <p>...90,100</p>		72.0	900	
					73.0		
 <p>...100,180 180 → 0,5xD</p>	 <p>...58,300 300 →</p>	 <p>...095,100</p>	 <p>...90,100</p>		74.0		950
					75.0		
 <p>...100,330 330 → 2xD</p>	 <p>...58,300 300 →</p>	 <p>...095,100</p>	 <p>...90,100</p>		76.0	950	
					77.0		
 <p>...100,330 330 → 2xD</p>	 <p>...58,300 300 →</p>	 <p>...095,100</p>	 <p>...90,100</p>		78.0		950
					79.0		
 <p>...100,330 330 → 2xD</p>	 <p>...58,300 300 →</p>	 <p>...095,100</p>	 <p>...90,100</p>		80.0	950	
					81.0		
 <p>...100,180 180 → 0,5xD</p>	 <p>...58,300 300 →</p>	 <p>...085,090</p>	 <p>...80,090</p>		82.0		850
					83.0		
 <p>...100,180 180 → 0,5xD</p>	 <p>...58,300 300 →</p>	 <p>...085,090</p>	 <p>...80,090</p>		84.0	850	
					85.0		
 <p>...100,180 180 → 0,5xD</p>	 <p>...58,300 300 →</p>	 <p>...085,090</p>	 <p>...80,090</p>		86.0		850
					87.0		
 <p>...100,180 180 → 0,5xD</p>	 <p>...58,300 300 →</p>	 <p>...085,090</p>	 <p>...80,090</p>		88.0	850	
					89.0		
 <p>...100,180 180 → 0,5xD</p>	 <p>...58,300 300 →</p>	 <p>...085,090</p>	 <p>...80,090</p>		90.0		900
					91.0		
 <p>...100,180 180 → 0,5xD</p>	 <p>...58,300 300 →</p>	 <p>...085,090</p>	 <p>...80,090</p>		92.0	900	
					93.0		
 <p>...100,180 180 → 0,5xD</p>	 <p>...58,300 300 →</p>	 <p>...085,090</p>	 <p>...80,090</p>		94.0		900
					95.0		
 <p>...100,180 180 → 0,5xD</p>	 <p>...58,300 300 →</p>	 <p>...085,090</p>	 <p>...80,090</p>		96.0	950	
					97.0		
 <p>...100,180 180 → 0,5xD</p>	 <p>...58,300 300 →</p>	 <p>...085,090</p>	 <p>...80,090</p>		98.0		950
					99.0		
 <p>...100,180 180 → 0,5xD</p>	 <p>...58,300 300 →</p>	 <p>...085,090</p>	 <p>...80,090</p>		100.0	950	

* for cartridge arrangement see page 19

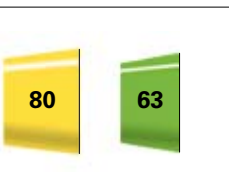

LT 800 • Overview of inserts and drill head arrangements

Central interchangeable inserts



Guhring no.	2747	1047	2485
Tool material	Solid carbide	Solid carbide	Solid carbide
Carbide grade	K	K/P	K/P
Surface finish	○	Ⓢ	ⓕ
predominantly suitable for	cast materials aluminium/Al-alloys plastics	universal machining of steel and cast materials	universal machining of steel and cast materials

External indexable inserts Type CCHX (outer)

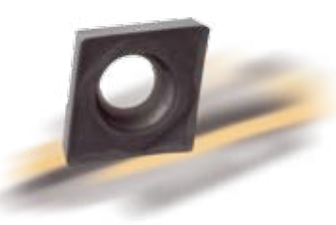

Guhring no.	4179	4180	4181	4182
Design	with circular land	with circular land	with circular land	with circular land
Tool material	Solid carbide	Solid carbide	Solid carbide	Solid carbide
Carbide grade	N15	K10	P25	M35
Surface finish	○	Ⓢ	Ⓢ	Ⓢ
predominantly suitable for	aluminium/Al-alloys plastics	cast materials	universal machining of steel and cast materials	C-steels, stainless and acid resistant steels
Size				
Size				

Type LTT (inner)

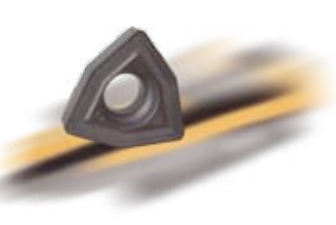

Guhring no.	4170	4171	4172	4173
Design	with circular land	with circular land	with circular land	with circular land
Tool material	Solid carbide	Solid carbide	Solid carbide	Solid carbide
Carbide grade	N10	K10	P25	P40
Surface finish	○	○	Ⓢ	Ⓐ
predominantly suitable for	nonferrous metals, Al/Al-alloys, plastics	cast materials	universal machining of steel and cast materials	C-steels, stainless and acid resistant steels
Size				
Size				

- bright
- Ⓢ TiN-coated
- ⓕ FIRE-coated
- Ⓐ TiAlN-coated

Cartridges for mounting external indexable inserts

(2 cartridges per drill head)

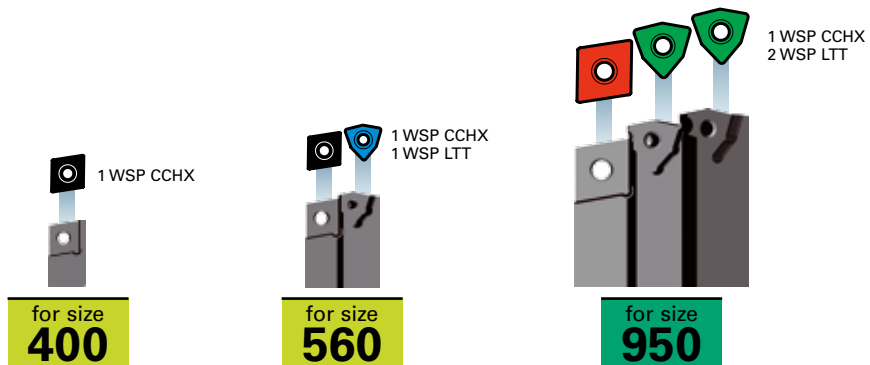

Drill heads (arrangement examples)

(arrangement overview of all sizes on page 19)

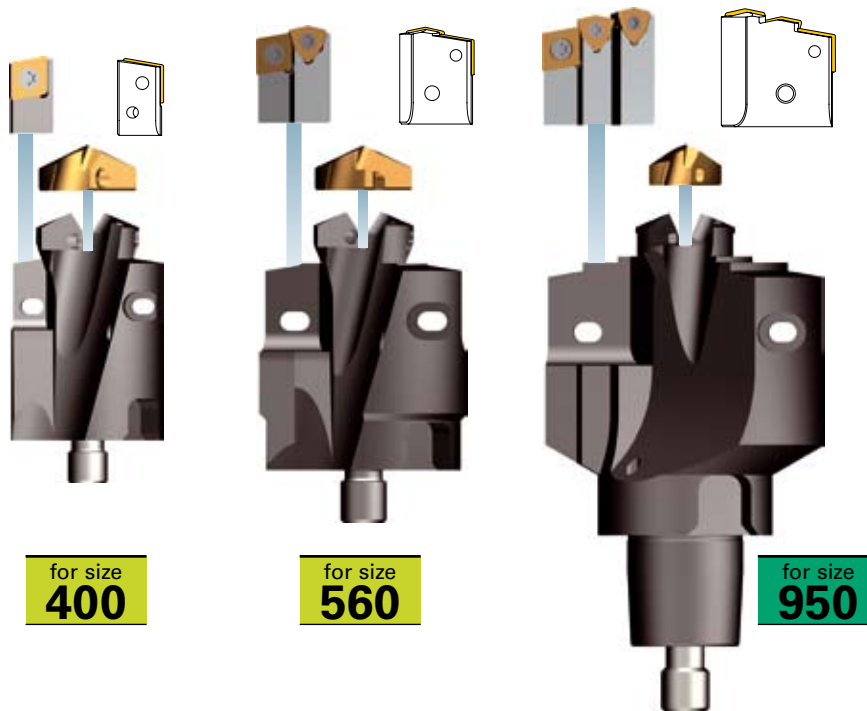

Diameter adjustment with distance piece on both sides

(using holder size 950 as an example)

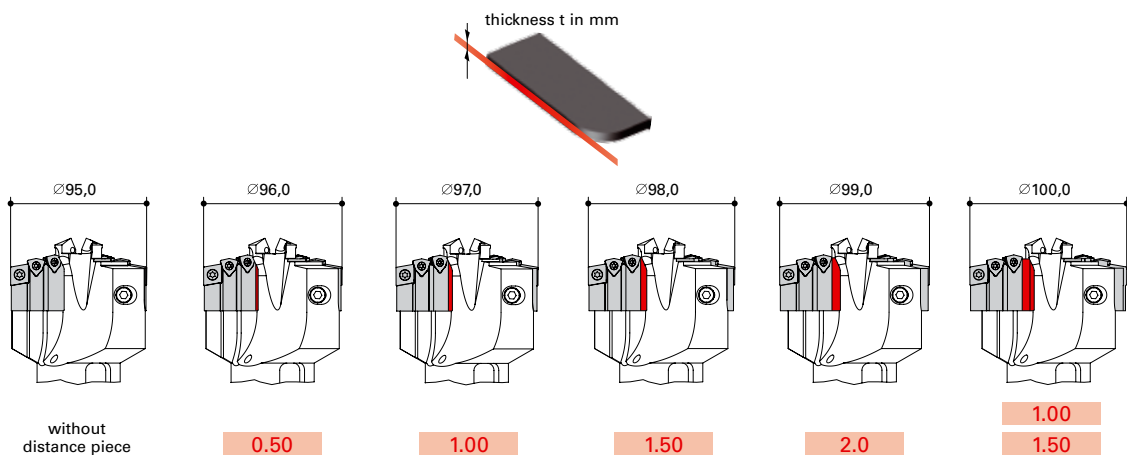

LT 800 · Representative program selection with drilling depth

Ø-range 40 ... < 60 mm

~ 1.5 x D

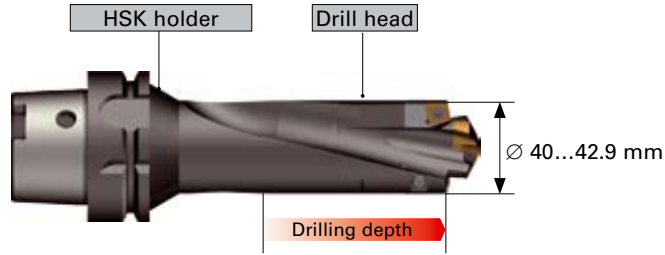

4142-63.105

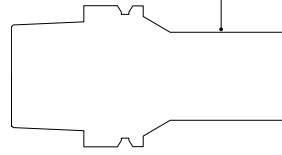

~ 3 x D

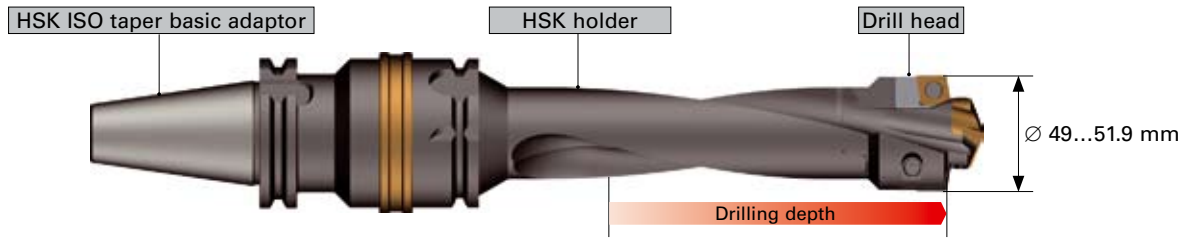

~ 12 x D



Ø-range 60 ... 100 mm

~ 2 x D

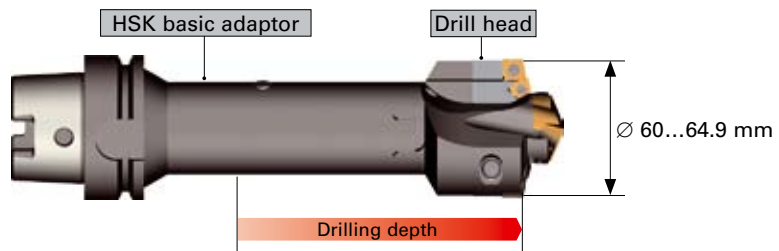

~ 3 x D



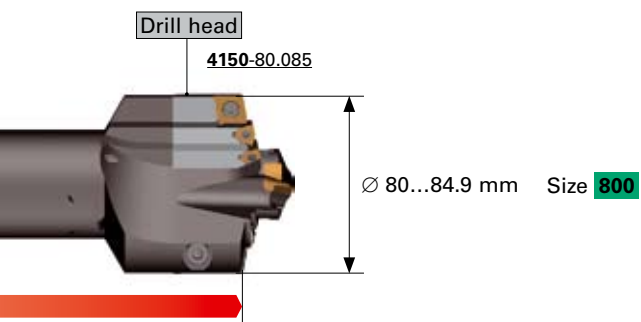
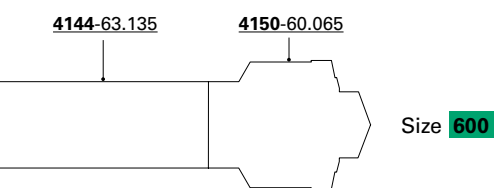
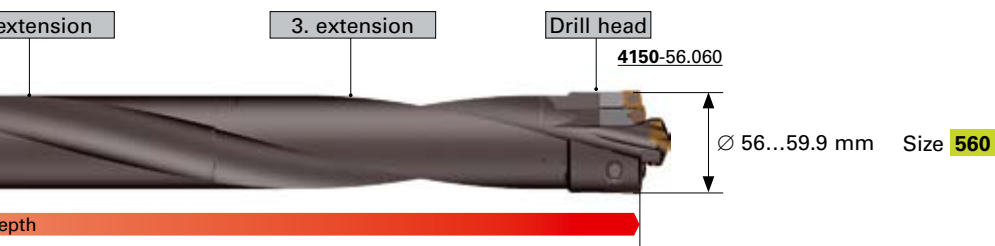
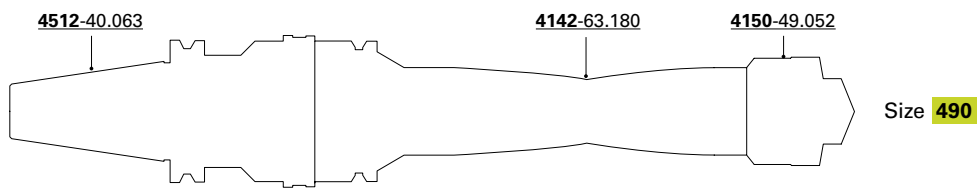
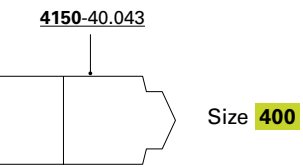

LT 800·Program

(for further basic adaptors, reductions and extensions see Guhring catalogue "GM 300")

ISO-taper basic adaptors (DIN 69871, form AD)

Guhring no. **4512**

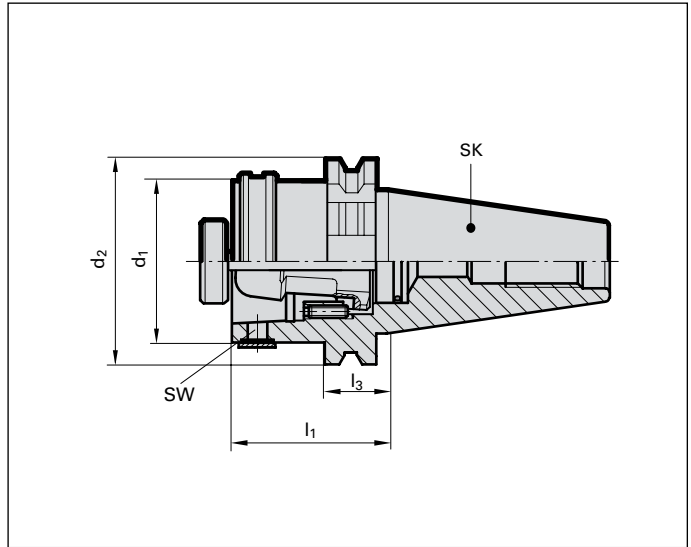

Guhring no. code no.	ISO-taper	HSK-C d1 mm	d2 mm	l1 mm	l3 mm	SW	Weight kg
4512 40,063	40	63	63.5	70	19.05	5.0	1.38
4512 50,063	50	63	97.5	40	19.05	5.0	2.73
4512 50,080	50	80	97.5	70	19.05	6.0	3.70
4512 60,100	60	100	155.0	50	19.05	8.0	9.70

Note: Please order retention bolt separately

Basic adaptors (VDI) (DIN 69880-1)

Guhring no. **4510**

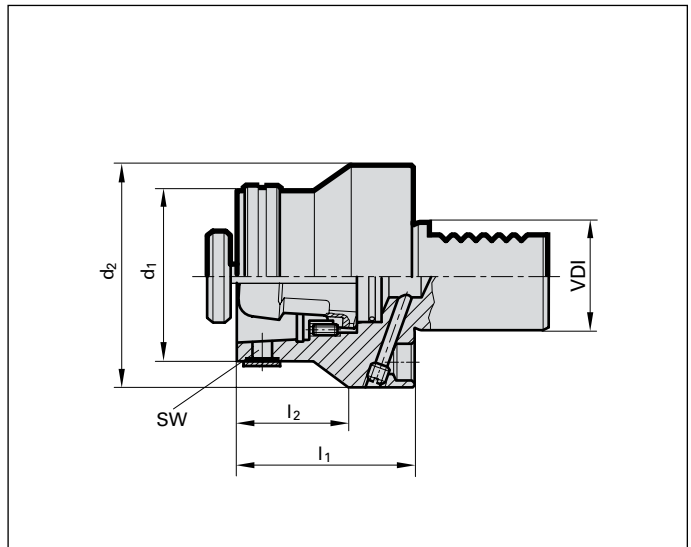

Guhring no. code no.	VDI-size	HSK-C d1 mm	d2 mm	l1 mm	l2 mm	SW	Weight kg
4510 40,063	40	63	83	80	50	5	2.38
4510 50,063	50	63	98	80	50	5	4.21
4510 50,080	50	80	98	100	70	6	5.00
4510 60,080	60	80	123	100	62	6	8.10
4510 60,100	60	100	123	125	87	8	9.70

HSK reductions

Guhring no. **4355**

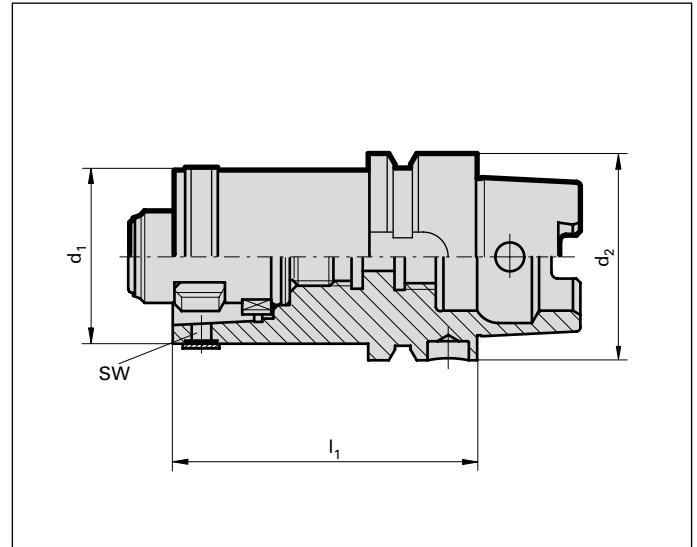

Guhring no. code no.	HSK-C d1 mm	HSK-A d2 mm	l1 mm	SW	Weight kg
4355 63,080	63	80	100	5	2.69
4355 63,100	63	100	100	5	3.31
4355 80,100	80	100	120	6	5.13

HSK extensions

Guhring no. **4549**

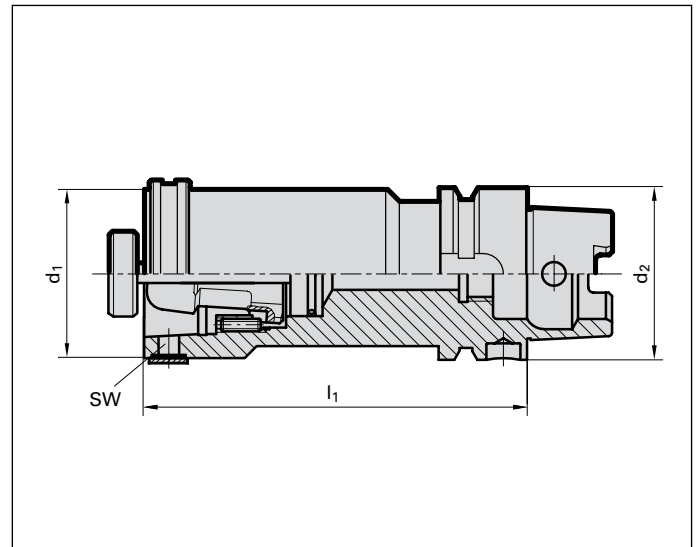

Guhring no. code no.	HSK-A d1/d2 mm	l1 mm	SW	Weight kg
4549 100,063	63	100	4	1.84
4549 140,063	63	140	4	2.30
4549 120,080	80	120	5	3.90
4549 160,080	80	160	5	5.40
4549 140,100	100	140	6	7.80
4549 200,100	100	200	6	10.54

HSK holders, with 15° spiral flutes

Guhring no. **4142**

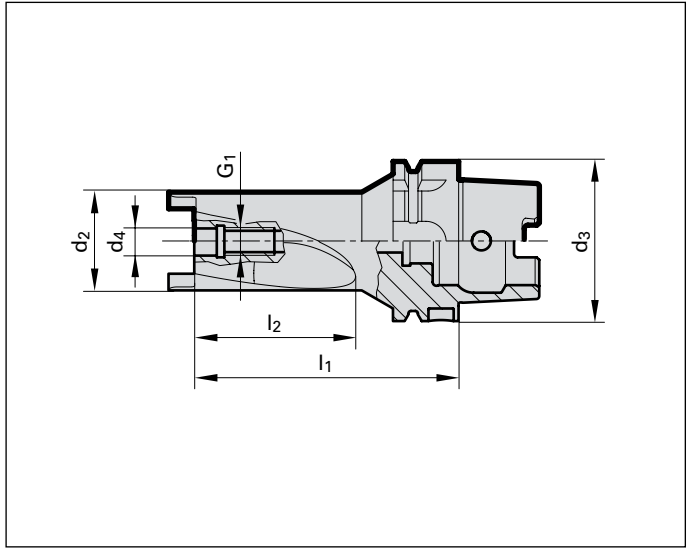

Guhring no. code no.	for holder size	d ₂ mm	HSK-A		d ₄ mm	l ₁ mm	l ₂ mm	Thread G ₁	Weight kg
			d ₃ mm						
4142 63,105	400...490	38.7	63		10.5	105	65	M10	1.2
4142 63,180	400...490	38.7	63		10.5	180	140	M10	1.5
4142 63,120	520/560	50.7	63		12.5	120	88	M12	1.6
4142 63,210	520/560	50.7	63		12.5	210	178	M12	2.4

HSK holders, without flutes

Guhring no. **4144**

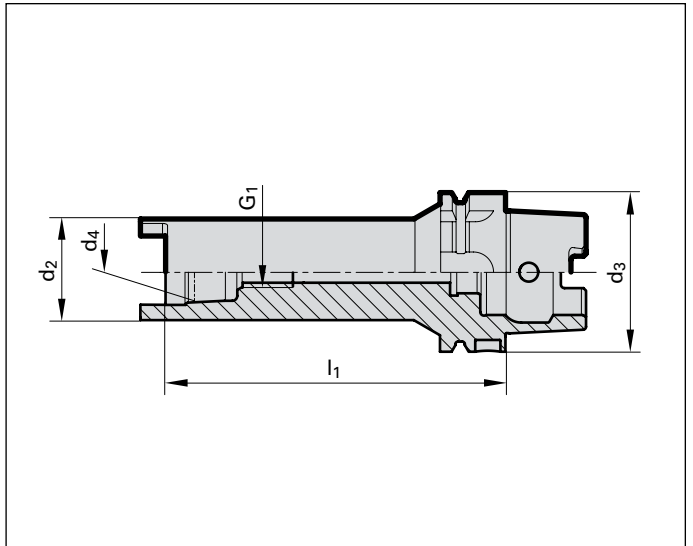

Guhring no. code no.	for holder size	d ₂ mm	HSK-A		d ₄ mm	l ₁ mm	Thread G ₁	Weight kg
			d ₃ mm					
4144 63,135	600/650	40	63		24	135	M14	1.6
4144 63,240	600/650	40	63		24	240	M14	2.6
4144 80,160	700...800	48	80		30	160	M16	2.8
4144 80,290	700...800	48	80		30	290	M16	4.5
4144 100,180	850...950	58	100		38	180	M16	4.8
4144 100,330	850...950	58	100		38	330	M16	7.8

Extensions, with 15° spiral flutes

Guhring no. **4148**

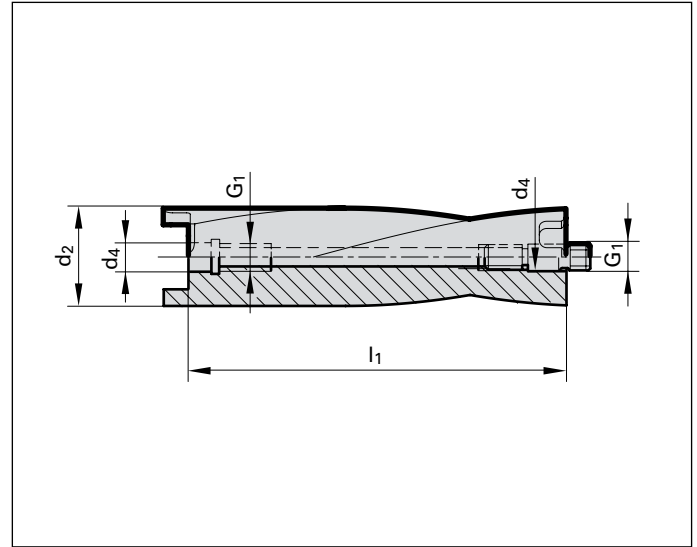

Guhring no. code no.	for holder size	d ₂ mm	d ₄ mm	l ₁ mm	Thread G ₁	Weight kg
4148 10,150	400...490	38.7	10.5	150	M10	0.8
4148 12,180	520/560	50.7	12.5	180	M12	1.7

Extensions, without flutes

Guhring no. **4149**

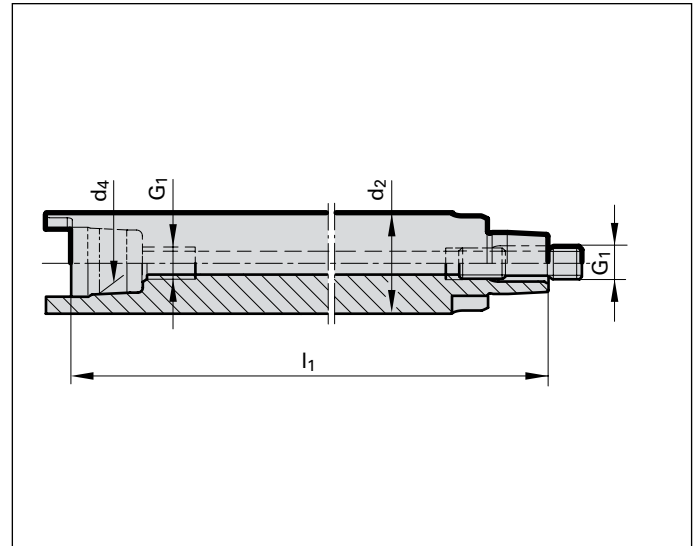

Guhring no. code no.	for holder size	d ₂ mm	d ₄ mm	l ₁ mm	Thread G ₁	Weight kg
4149 40,210	600/650	40	24	210	M14	1.9
4149 48,255	700...800	48	30	255	M16	3.3
4149 58,300	850...950	58	38	300	M16	5.7

Drill heads (incl. retention spindle)

Guhring no. **4150**

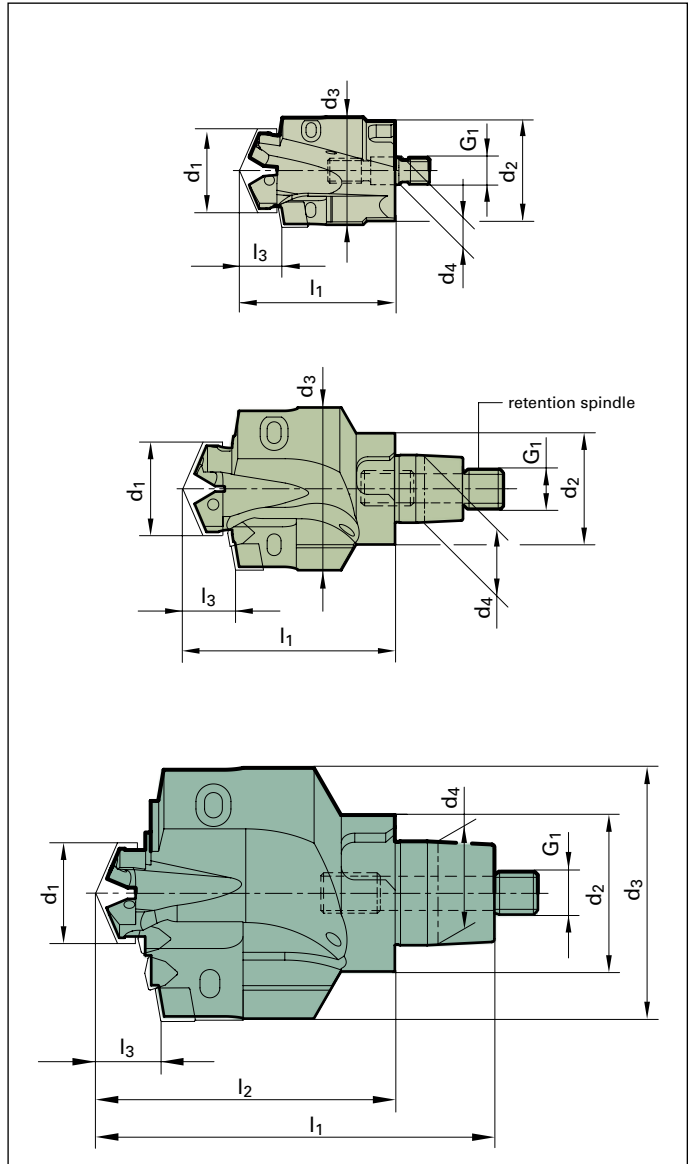

Guhring no. code no.	for holder size	interch. insert d ₁ mm	for cartridge arrangement with	d ₂ mm	d ₃ mm	d ₄ mm	l ₁ mm	l ₂ mm	l ₃ mm	Thread G ₁	Weight kg
4150 40,043	400	27	1 ind. insert	38.7	38.7	10.5	60	–	14	M10	0.20
4150 43,046	430	30	1 ind. insert	38.7	41.7	10.5	60	–	15	M10	0.22
4150 46,049	460	28	1 ind. insert	38.7	44.7	10.5	60	–	15	M10	0.22
4150 49,052	490	31	1 ind. insert	38.7	47.7	10.5	60	–	16	M10	0.24
4150 52,056	520	34	1 ind. insert	50.7	50.7	12.5	70	–	18	M12	0.39
4150 56,060	560	27	2 ind. inserts	50.7	54.5	12.5	70	–	17	M12	0.41
4150 60,065	600	32	2 ind. inserts	40.0	58.5	24.0	99	75	18	M14	0.63
4150 65,070	650	32	2 ind. inserts	40.0	63.5	24.0	104	80	19	M14	0.73
4150 70,075	700	32	2 ind. inserts	48.0	68.5	30.0	115	85	20	M16	0.98
4150 75,080	750	32	3 ind. inserts	48.0	73.5	30.0	130	100	23	M16	1.21
4150 80,085	800	32	3 ind. inserts	48.0	78.5	30.0	130	100	23	M16	1.24
4150 85,090	850	34	3 ind. inserts	58.0	83.5	38.0	142	105	21	M16	1.70
4150 90,095	900	32	3 ind. inserts	58.0	88.5	38.0	147	110	25	M16	1.90
4150 95,100	950	34	3 ind. inserts	58.0	93.5	38.0	147	110	23	M16	2.10

Retention spindles (Torx screws)

Guhring no. **4164**

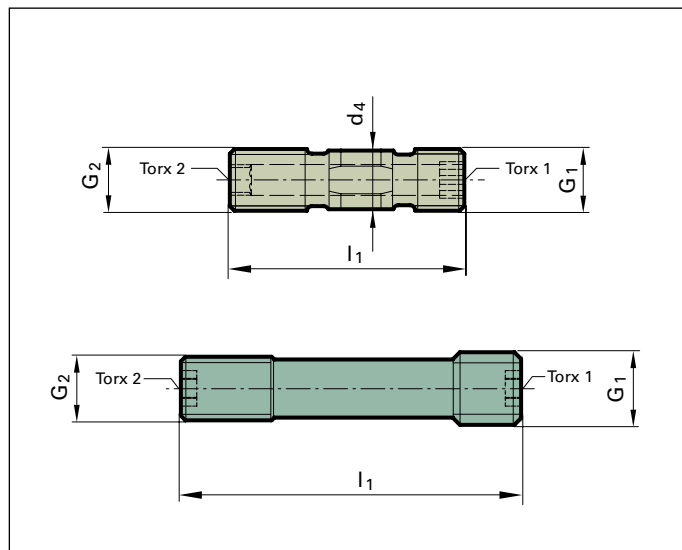

Guhring no. code no.	for holder size	d ₄ mm	l ₁ mm	Torx size		Thread	
				TX1	TX2	G ₁	G ₂
4164 40,052	400...490	10,5	38	T40	T30	M10	M10x1
4164 52,060	520/560	12,5	45	T45	T30	M12	M12x1
4164 60,070	600/650	–	55	T45	T45	M14	M14x1
4164 70,085	700...800	–	65	T45	T45	M16	M14x1
4164 85,100	850...950	–	75	T45	T45	M16	M14x1

Torx driver sockets (retention spindle)

Guhring no. **4188**

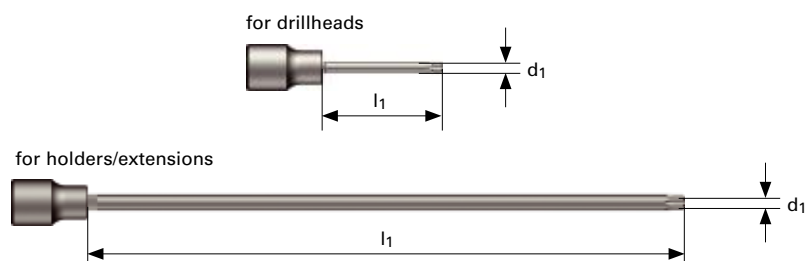

Guhring no. code no.	Driver sockets suitable for	Torx d ₁ mm	l ₁ mm	Guhring no. code no.	Driver sockets suitable for	Torx d ₁ mm	l ₁ mm
4188 30,060	Drill heads	T30	60	4188 45,105	Drill heads	T45	105
4188 30,210	Holders and extensions	T30	210	4188 45,300	Holders and extensions	T45	300
4188 40,180		T40	180				

Torque wrench for Torx driver sockets Guhring no. 4188 Guhring no. **4915**

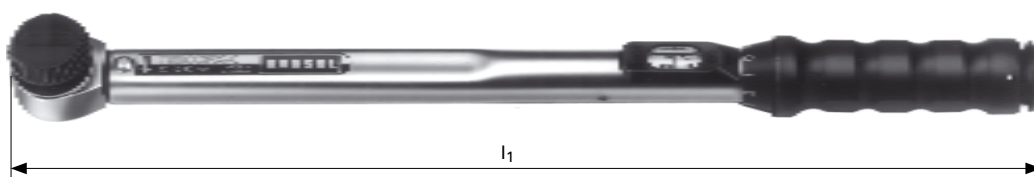

Guhring no. code no.	Application	Type	Drive	l ₁ mm	Torque Nm
4915 200,000	Drill heads, holders and extension	C	1/2" ■	480	20...200

Cartridges for external indexable inserts

Guhring no. **4160**



Guhring no. code no.	for holder size	no. of indexable inserts	b mm	l ₁ mm
4160 40,046	400/430	1	11.0	19.5
4160 46,056	460...520	1	14.0	23.6
4160 56,065	560 600	2	18.2	25.4
4160 65,070	650	2	21.0	25.4
4160 70,075	700	2	23.9	29.4

Guhring no. code no.	for holder size	no. of indexable inserts	b mm	l ₁ mm
4160 75,080	750	3	23.3	35.5
4160 80,090	800/850	3	26.0	39.0
4160 90,100	900/950	3	30.2	39.0

Clamping screws for index. inserts

No. **4189**

Fastening screws for cartr. DIN EN ISO 4762

No. **4907**

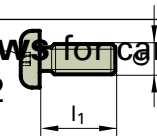

Guhring no. code no.	for holder size	l ₁ mm	G	Torx
4189 003,500	400/430	9.4	M3.5	T10
4189 004,000	460...520	10.0	M4	T15
4189 004,500	560 600/650	12.0	M4.5	T15

Guhring no. code no.	for holder size	l ₁ mm	G	SW
4907 005,161	700	16	M5	SW4
4907 006,141	750	14*	M6	SW5
4907 006,161	800/850	16	M6	SW5
4907 006,201	900/950	20	M6	SW5

Serrated lock washers extern. toothed

No. **4102**

Distance pieces (sets)

No. **4168**

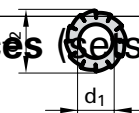

Guhring no. code no.	for holder size	d ₁ mm	d ₂ mm
4102 003,700	400/430	3.7	7
4102 004,300	460...520	4.3	8
4102 005,100	560 600/650	5.1	9
4102 005,300	700	5.3	10
4102 006,400	750...950	6.4	11

Guhring no. code no.	for holder size	l ₁ mm	b mm	No.(x2)/thickness s mm
4168 040,046	400/430	18.5	8.5	0.5/1.0/1.5
4168 046,056	460...520	22.5	9.5	0.5/1.0/1.5/2.0
4168 056,070	560 600/650	22.5	11.0	0.5/1.0/1.5/2.0
4168 070,075	700	26.5	11.5	0.5/1.0/1.5/2.0
4168 075,080	750	33.0	13.5	0.5/1.0/1.5/2.0
4168 080,090	800/850	36.5	13.5	0.5/1.0/1.5/2.0
4168 090,100	900/950	36.0	15.0	0.5/1.0/1.5/2.0

LT 800 tools for special applications

1. Cartridges for drilling stacked sheets

Drilling stacked sheets (e.g. for heat exchanger) with the standard range is only possible from $\varnothing 40 \dots 55.9$ mm due to the positioning of the indexable inserts in the cartridge. Illustrated below are cartridges required for $\varnothing 56 \dots 100$ mm, available on request.

560...700

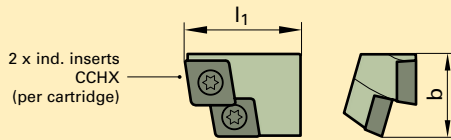

for holder size	l_1 mm	b mm
560/600	25.4	18.2
650	25.4	21.0
700	29.4	23.9

750...950

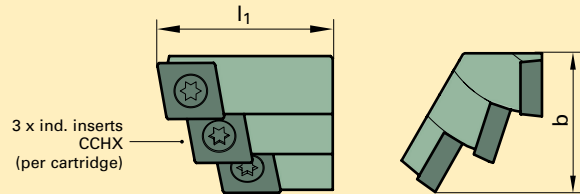

for holder size	l_1 mm	b mm
750	35.5	23.3
800/850	39.0	26.0
900/950	39.0	30.2

2. Special tools (example selection)

Tool for the machining of a welded workpiece fitted with solid carbide, FIRE-coated inserts
 Material: St52
 Diameter: 49 mm
 followed by fineboring
 Diameter: 50 H7 mm

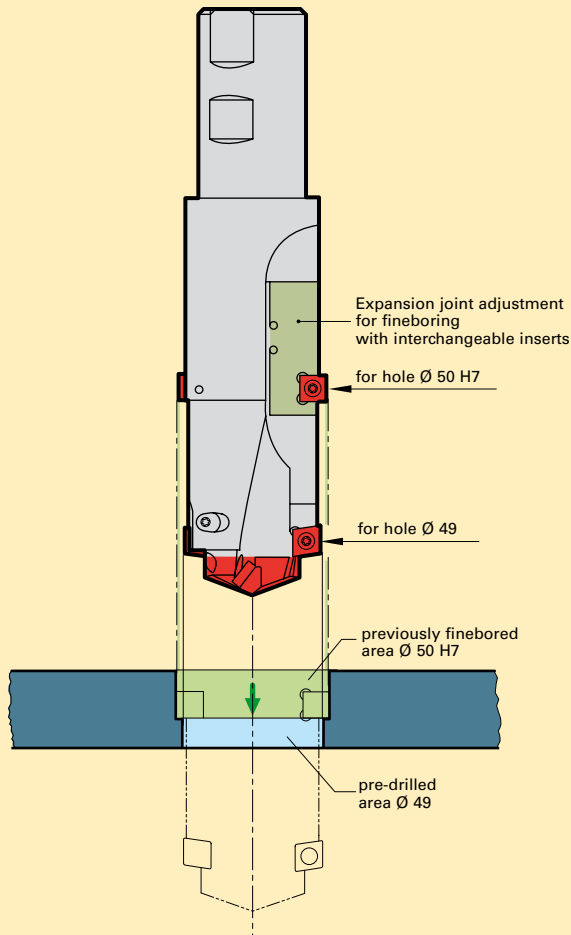

Tool for the machining (solid drilling) of a cylinder crankcase fitted with solid carbide, FIRE-coated inserts
 Material: CGI
 Diameter: 76 mm
 followed by reverse circular milling
 Chamfer 1.5 x 45° at $\varnothing 76$ mm

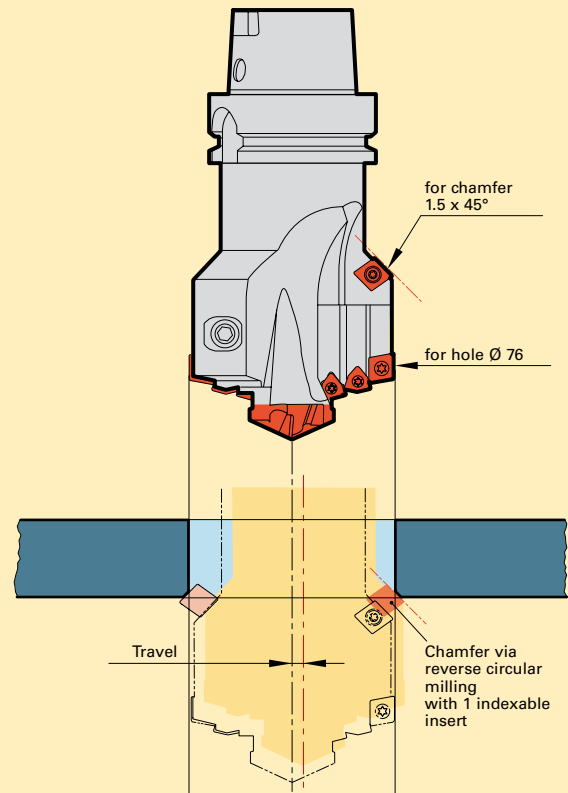



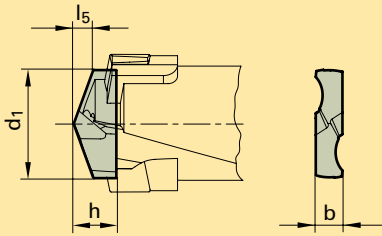

Central interchangeable inserts and accessories

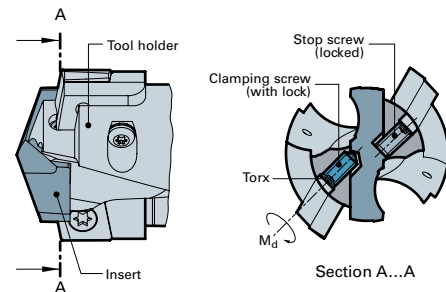

Form accurate fit of the interchangeable insert ensures safe clamping in holder.

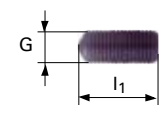

Torx size	Ø-range mm	Torque M _d (Ncm)
T8	>25.5 - 34.5	180

Interchangeable inserts incl. clamping screw					Clamping screws				Screwdriver	
Guhring no.	2747	1047	2485		1071				1612	
Tool material	Solid carbide									
Carbide grade	K									
Surface finish	○									
										
for holder size	Nom.-∅ d ₁ h ₇ mm	Cutting point l ₅ mm	Width b mm	Height h mm	Thread G	Code no.	Length l ₁ mm	with Torx	Code no.	for Torx
400	27.00	4.9	7.3	11.6	M4x0.5	4,000	9.00	T8	8,001	T8
560	28.00	5.1	7.3	11.6						
460	30.00	5.5	8.5	13.6						
430	31.00	5.6	8.5	13.6						
490	32.00	5.8	8.5	13.6						
600	32.00	5.8	8.5	13.6	M4.5x0.5	4,500	10.00	T8	8,001	T8
650										
700										
750										
800										
900	34.00	6.2	8.5	13.6						
520										
850										
950										

Torx bits

Guhring no. **4917** Torque wrench



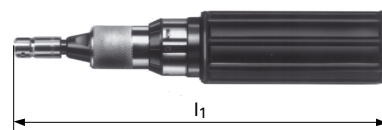



Guhring no. **4915**



Guhring no. code no.	for Torx	Drive	l ₁ mm	Guhring no. code no.	Type	Drive	l ₁ mm	Torque Nm
4917 8,000	T8	1/4" 	25	4915 5,001	A	1/4"	160	1...5





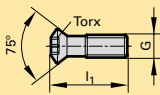
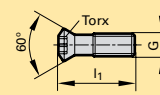

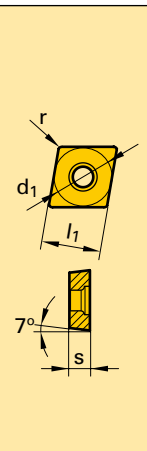
○ bright **S** TiN-coated **F** FIRE-coated **A** TiAlN-coated

External indexable inserts Type CCHX (outer)







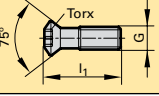

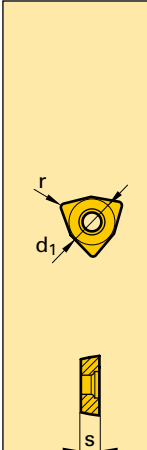













Guhring no.		4179	4180	4181	4182	
Code no.	Size 09	093,080	093,080	093,080	093,080	
	Size 12	124,080	124,080	124,080	124,080	
Tool material		Solid carbide	Solid carbide	Solid carbide	Solid carbide	
Carbide grade		K10	K10	P25	M35	
Surface finish		○	Ⓢ	Ⓢ	Ⓢ	
						
Indexable insert size	Indexable insert description code no.	Incircle d ₁ mm	Corner radius r mm	Thickness s mm	Length l ₁ mm	
 09	CCHX09T308	9.525	0.8	3.97	9.35	
 12	CCHX120408	12.700	0.8	4.76	12.50	
Clamping screws						
Guhring no.		4166		6128		
						
for indexable insert size	Guhring no. code no.	No. of indexable inserts	for holder size	Length l ₁ mm	Thread G mm	Torx size
09	4166 3,500	2	400/430 560...650, 750	7.3	M3.5	T10
12	6128 4,501	2	460...520, 700 800...950	7.5	M4.5	T15

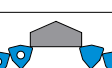

Type LTT (inner)

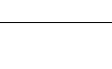
Guhring no.		4170	4171	4172	4173	
Code no.	Size 05	053,040	053,080	053,080	053,040	
	Size 06	063,040	063,080	063,080	063,040	
Tool material		Solid carbide	Solid carbide	Solid carbide	Solid carbide	
Carbide grade		N15	K10	P25	M35	
Surface finish		○	○	Ⓢ	Ⓐ	
						
Indexable insert size	of Guhring no.	Indexable insert description	Incircle d ₁ mm	Corner radius r mm	Thickness s mm	
 05	4170	LTT05T304	8.0	0.4	3.8	
	4173	LTT05T308		0.8		
 06	4170	LTT06T304	10.0	0.4	3.8	
	4173	LTT06T308		0.8		
Clamping screws						
Guhring no.		4166				
						
for indexable insert size	Guhring no. code no.	No. of indexable inserts	for holder size	l ₁ mm	Thread G mm	Torx size
05	4166 2,500	2	560/600	7,4	M2,5	T8
		4	750...850			
06	4166 3,500	2	650/700	7,3	M3,5	T10
		4	900/950			

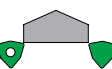

Insert arrangement overview		
Holder size	Central insert ∅	Indexable insert arrangement
400		
430		
460		
490		
520		
560		
600		
650		
700		
750		
800		
850		
900		
950		

LT 800·Assembly Instructions

for $\varnothing 40...< 60$ mm (size 400...560)

1. Assembly of the tool body

1.1. Assembly without extension

Connect the drill head to the holder via the retention spindle (double-ended Torx fitting).
The correct extension for the Torx screw is required (see page 15)! Via the holder the retention spindle is then locked in **anticlockwise** direction and tightened to a recommended torque of $M_A = 25$ Nm.
Check dimension "x".

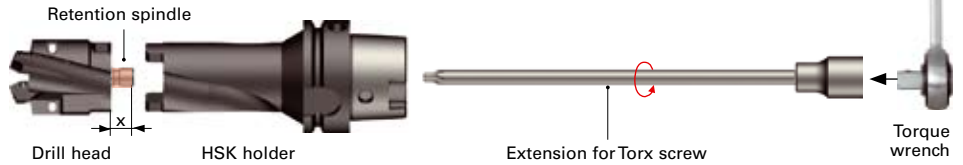
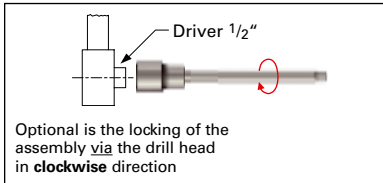

1.2. Assembly with extension

First, fit the extension to the holder in **clockwise** direction.
Optional, see 1.1., is the locking via the holder in **anticlockwise** direction.



Then, to complete the assembly, fit the drill head to the extension in **clockwise** direction.

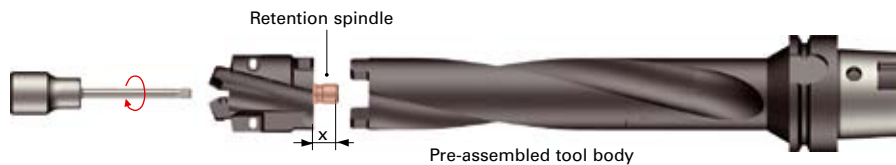

1.3. Important notes

To fit retention spindle:
Torque wrench
Guhring no. 4915 200,000 (Driver 1/2")
Torque $M_A = 25$ Nm

Retention spindle assembly length Dimension x in mm			
for size	\varnothing -range	dim.x	
400...490	$\varnothing 40.0...51.9$	13.5	
520/560	$\varnothing 52.0...59.9$	17.0	



- If new assembly, grease retention spindle (double-ended Torx fitting) with MOS 2 paste (prod. no. 400 118 396) at both ends (tool is supplied pre-greased!)
- Check dimension x and correct if necessary!
- Pay attention to position of driver to flute!

2. Assembly of cartridges and indexable inserts

2.1. Insert distance piece

If increase in \varnothing is required, insert identical distance pieces (left and right).
If basic \varnothing modification is not required, continue and go to point 2.2. (see also page 7).

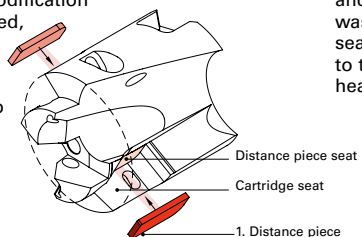

2.2. Cartridge assembly

Fit cartridge to the drill head using the fastening screws and the serrated lock washers. Ensure a seamless fitment to the drill head!

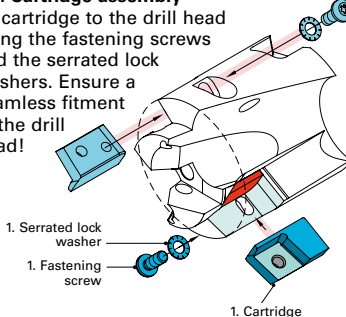

2.3. Fitting the indexable inserts

Fit the indexable inserts to the cartridges using the supplied clamping screws.

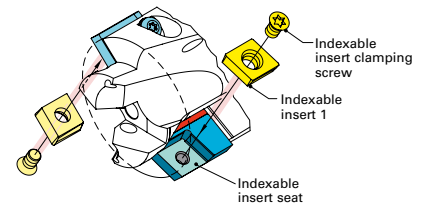

3. Central insert installation

3.1. Position central insert in insert seat

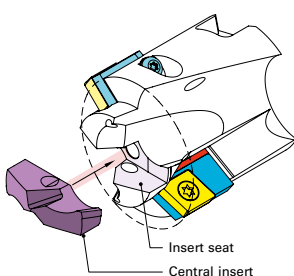

3.2. Fasten insert

with supplied clamping screw (Torque 180 Ncm).
Replace clamping screw after every insert change.

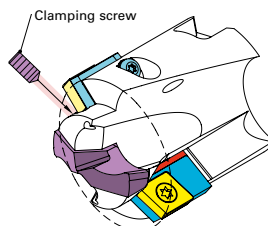

Safety recommendations:

- with rotating workpieces, a disc is created on hole break through. Due to the centrifugal effect there is a possible risk of accident. Safety precautions must be followed.
- in order to prevent damage to machine and tool, we recommend the prior determination of the required power and torque.

Accessories for the central insert installation:

- Clamping screw, Torx 8, Guhring no. 1071 4,000/4,500 Torque 180 Ncm
- Torque wrench, Guhring no. 4915 5,000
- Torx-bit, Guhring no. 4917 8,000

for \varnothing 60...100 mm (size 600...950)

1. Assembly of the tool body

1.1. Assembly without extension

Connect the drill head to the holder via the retention spindle (double-ended Torx fitting). The correct extension for the Torx screw is required (see page 15)! Via the holder the retention spindle is then locked in **anticlockwise** direction and tightened to a recommended torque of $M_A = 50$ Nm. Check dimension "x":

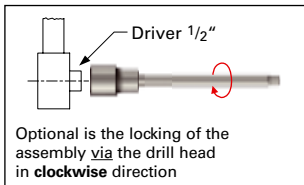

1.2. Assembly with extension

First, fit the extension to the holder in **clockwise** direction

Optional, see 1.1., is the locking via the holder in **anticlockwise** direction.

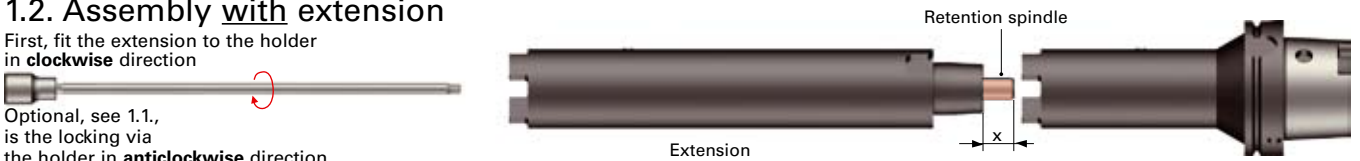

Then, to complete the assembly, fit the drill head to the extension in **clockwise** direction.

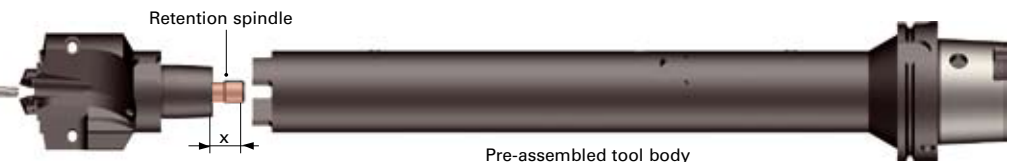

1.3. Important notes

To fit retention spindle:
Torque wrench
Guhring no. 4915 200,000 (Driver 1/2")
Torque $M_A = 50$ Nm

Retention spindle assembly length Dimension x in mm		
for size	\varnothing -range	dim.x
600/650	\varnothing 60.0...69.9 =	11.0
700...800	\varnothing 70.0...84.9 =	13.0
850...950	\varnothing 85.0...100 =	14.0



- If new assembly, grease retention spindle (double-ended Torx fitting) with MOS 2 paste (prod. no. 400 118 396) at both ends (tool is supplied pre-greased!)
- Check dimension x and correct if necessary!
- Pay attention to position of driver to flute!

2. Assembly of cartridges and indexable inserts

2.1. Insert distance piece

If increase in \varnothing is required, insert identical distance pieces (left and right). If basic \varnothing modification is not required, continue and go to point 2.2. (see also page 7).

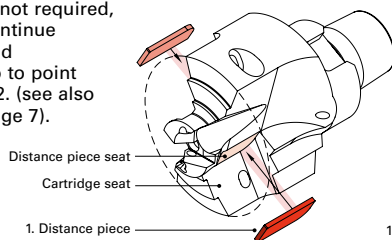

2.2. Cartridge assembly

Fit cartridge to the drill head using the fastening screws and the serrated lock washers. Ensure a seamless fitment to the drill head!

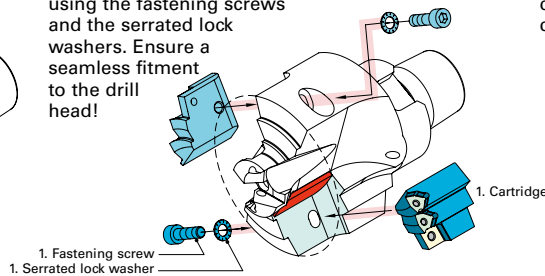

2.3. Fitting the indexable inserts

Fit the indexable inserts to the cartridges using the supplied clamping screws.

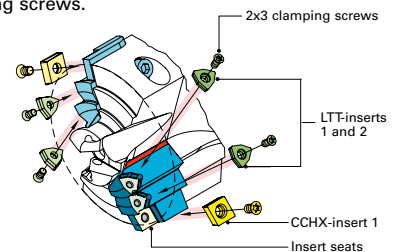

3. Central insert installation

3.1. Position central insert in insert seat

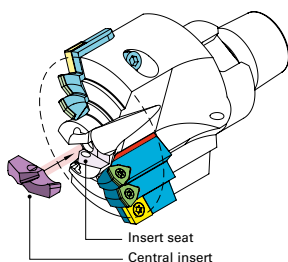

3.2. Fasten insert

with supplied clamping screw (Torque 180 Ncm). Replace clamping screw after every insert change.

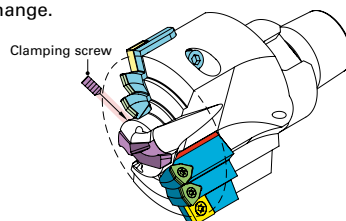

Safety recommendations:

- with rotating workpieces, a disc is created on hole break through. Due to the centrifugal effect there is a possible risk of accident. Safety precautions must be followed.
- in order to prevent damage to machine and tool, we recommend the prior determination of the required power and torque.

Accessories for the central insert installation:

- Clamping screw, Torx 8, Guhring no. 1071 4,500 Torque 180 Ncm
- Torque wrench, Guhring no. 4915 5,001
- Torx-bit, Guhring no. 4917 8,000

Required coolant pressure and volume

The optimal, good and minimum required coolant volumes shown in the diagrams apply only to LT 800-tools and are not machine dependent. The pressure values in contrast are dependent on the machine, because machines are equipped with different cooling systems and subsequently have different leakage characteristics. Therefore, the pressure values illustrated serve only for information and assessing the size of volume.

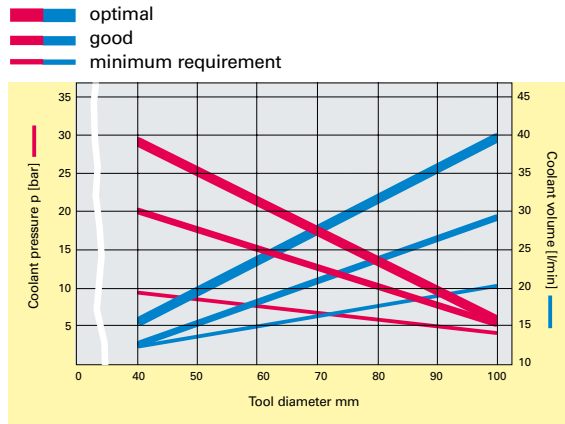

Recommended values for the machining of steel

Workpiece material: unalloyed heat treatable steel
 Tensile strength: 700...800 N/mm²
 Cutting speed: 100 m/min

Feed force loading

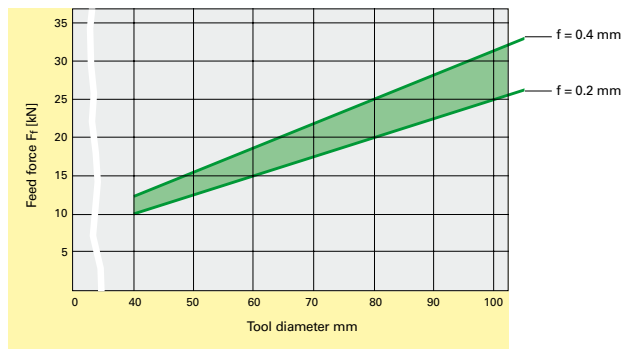

Power requirement

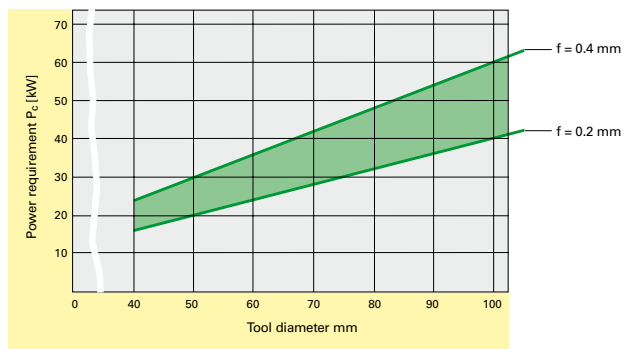

Torque requirement

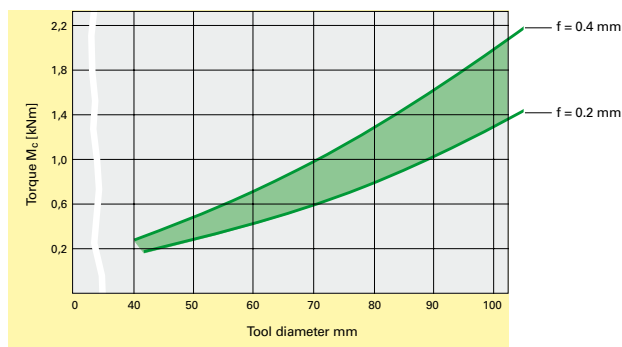

Performance Comparison

1

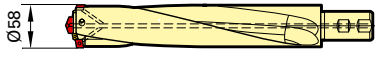
Tools	LT 800 Guhring no.	Competitor ind. ins. drill
		
Central interchangeable insert (WP)	2485 (F)	
1. Indexable inserts (WSP), inner	4172 (S) LTT 05T308	
2. Indexable inserts (WSP), outer	4181 (S) CCHX09T308Rf	
Holder for drilling depth	5xD	
Holder	DIN 1835	
Workpiece	Main spindle	
Machine	CNC-lathe GILDEMEISTER	
Workpiece material	31Cr MoV9 (1,8519)	
Hole-Ø mm	58	
Drilling depth mm	300	
Number of holes	1 (per spindle)	
Cutting parameters		
Cutting speed v_c (m/min)	70	120
Feed rate f (mm/rev.)	0.25	0.10

Result:

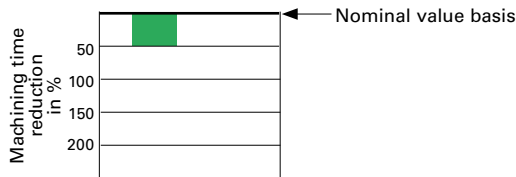

3

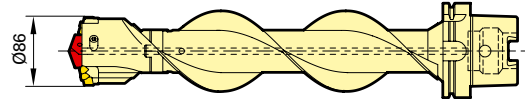
Tools	LT 800 Guhring no.	Competitor ind. ins. drill
		
Central interchangeable insert (WP)	2485 (F)	
1. Indexable inserts (WSP), inner	4172 (S) DFT05T308	
2. Indexable inserts (WSP), centre	4172 (S) DFT05T308	
3. Indexable inserts (WSP), outer	4181 (S) CCMT09T304	
Holder for drilling depth	4xD	
Holder	HSK-A100	
Workpiece	Turbine housing	
Machine	WALDRICH	
Workpiece material	GS17CrMo5-5 (1.7357)	
Hole-Ø mm	86	
Drilling depth mm	320	
Number of holes	12 (per housing)	
Cutting parameters		
Cutting speed v_c (m/min)	106	160
Feed rate f (mm/rev.)	0.3	0.1

Result:

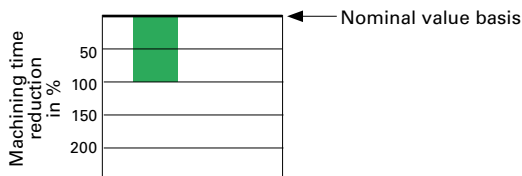

2

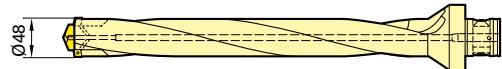
Tools	LT 800 Guhring no.	Competitor ind. ins. drill
		
Central interchangeable insert (WP)	1047 (S)	
Indexable insert (WSP)	4181 (S) CCHX09T308Rf	
Holder for drilling depth	8xD	
Holder	ABS-80	
Workpiece	Motor housing	
Machine	WALDRICH	
Workpiece material	GGG 40	
Hole-Ø mm	50	
Drilling depth mm	400	
Number of holes	72 (per housing)	
Cutting parameters		
Cutting speed v_c (m/min)	120	180
Feed rate f (mm/rev.)	0.6	0.16

Result:

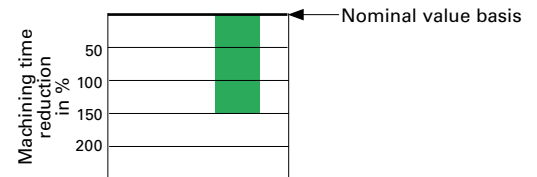

4

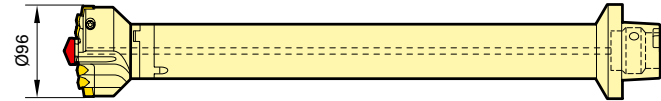
Tools	LT 800 Guhring no.	Competitor ind. ins. drill
		
Central interchangeable insert (WP)	2485 (F)	
1. Indexable inserts (WSP), inner	4172 (S) LTT06T304	
2. Indexable inserts (WSP), centre	4172 (S) LTT06T304	
3. Indexable inserts (WSP), outer	4181 (S) CCHX09T308	
Holder for drilling depth	4xD	
Holder	HSK-C80	
Workpiece	Extrusion shaft	
Machine	CNC-lathe VDF	
Workpiece material	14CrMoV6-9 (1.7735)	
Hole-Ø mm	96	
Drilling depth mm	300	
Number of holes	1 (per shaft)	
Cutting parameters		
Cutting speed v_c (m/min)	100	100
Feed rate f (mm/rev.)	0.3	0.12

Result:

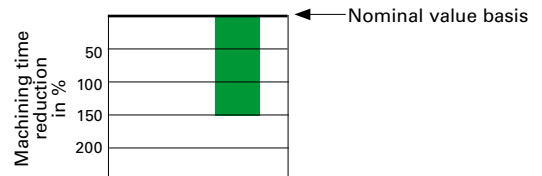

(S) TiN-coated

(F) FIRE-coated

GÜHRINGGUIDE · Application recommendations

- for through holes supporting lands of the outer indexable inserts must remain in permanent contact
- for drilling depths in excess of 7xD centering is recommended with equal point angle of 140°, or larger, to approximately 2/3 cutting edge diameter of the central interchangeable insert (do not apply standard centre drill to DIN332). If centering is impossible, spot-drill with reduced feed.
- interrupted cutting (cross holes, grooves, oblique entry/exit) is not recommended without prior tests. We recommend reducing the feed by approximately 50%.
- the standard LT800 tool system is also suitable for drilling up to diameter 55.9 mm in stacked metal sheets. For drilling of stacked metal sheets above diameter 56 mm, the standard cartridge must be replaced with a cartridge with a suitable indexable insert arrangement (see page 17).
- when replacing the central interchangeable insert (RT800), we recommend replacing the clamping screw with a new one (with clamping thread protection).
- with turning machines (vertical drilling tool) it must be ensured the tool operates precisely on centre.
- pre-requisite for optimal machining results is a sufficient coolant supply (see diagrams page 22). The tool possesses only limited suitability for dry machining or MQL. The cutting speed should be reduced by approximately 30% whilst retaining the same feed rate.

Safety recommendations:

- with rotating workpieces, a disc is created on hole break through. Due to the centrifugal effect there is a possible risk of accident! Safety precautions must be followed.
- in order to prevent damage to machine and tool, we recommend the prior determination of the required power and torque (see diagrams on page 22).

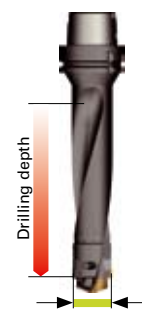

Material specific coolants:

- soluble oil
- neat oil
- air

Interchangeable insert material

Carbide grade

Holder sizes

Nom.-Ø range mm

Solid
dependent on int
400...560
40...<60

Material group	Material examples, new description (old description in brackets) <i>Figures in bold = material no. to DIN EN</i>	Tensile strength N/mm ²	Hard- ness	Cool- ant	Feed rate f (mm/rev.)	V _c m/min
Common structural steels	1.0035 S185 (St33), 1.0486 P275N (StE285), 1.0345 P235GH (H1), 1.0425 P265GH (H2) 1.0050 E295 (St50-2), 1.0070 E360 (St70-2), 1.8937 P500NH (WStE500)	≤500 >500-850		●	0.20...0.40 0.20...0.40	110...150 100...130
Free-cutting steels	1.0718 11SMnPb30 (9SMnPb28), 1.0736 11SMn37 (9SMn36) 1.0727 46S20 (45S20), 1.0728 (60S20), 1.0757 46SPb20 (45SPb20)	≤850 850-1000		●	0.20...0.40 0.15...0.30	110...150 100...130
Unalloyed heat treatable steels	1.0402 C22, 1.1178 C30E (Ck30) 1.0503 C45, 1.1191 C45E (Ck45) 1.0601 C60, 1.1221 C60E (Ck60)	≤ 700 700-850 850-1000		●	0.20...0.40 0.20...0.40 0.15...0.35	100...130 90...120 80...110
Alloyed heat treatable steels	1.5131 50MnSi4, 1.7003 38Cr2, 1.7030 28Cr4 1.5710 36NiCr6, 1.7035 41Cr4, 1.7225 42CrMo4	850-1000 1000-1200		●	0.20...0.40 0.15...0.35	80...110 70...100
Unalloyed case hardened steels	1.0301 (C10), 1.1121 C10E (Ck10)	≤750		●	0.20...0.40	90...120
Alloyed case hardened steels	1.7043 38Cr4 1.5752 15NiCr13 (15NiCr13), 1.7131 16MnCr5, 1.7264 20CrMo5	850-1000 1000-1200		●	0.20...0.40 0.15...0.35	80...110 70...100
Nitriding steels	1.8504 34CrAl6 1.8519 31CrMoV9, 1.8550 34CrAlNi7	≥850-1000 1000-1200		●	0.20...0.40 0.15...0.35	80...110 70...100
Tool steels	1.1750 C75W, 1.2067 102Cr6, 1.2307 29CrMoV9 1.2080 X210Cr12, 1.2083 X42Cr13, 1.2419 105WCr6, 1.2767 X45NiCrMo4	≤850 850-1000		●	0.20...0.40 0.15...0.35	70...100 70...90
High speed steels	1.3243 S 6-5-2-5, 1.3343 S 6-5-2, 1.3344 S 6-5-3	≥650-1000		●		
Spring steels	1.5026 55Si7, 1.7176 55Cr3, 1.8159 51CrV4 (51CrV4)		≤330 HB	●		
Stainless steel, sulphured austenitic	1.4005 X12CrS13, 1.4104 X14CrMoS17, 1.4105 X6CrMoS17, 1.4305 X8CrNiS18-9	≤850		●	0.15...0.35	70...100
Stainless steel, martensitic	1.4301 X5CrNi18-10, 1.4541 X6CrNiTi18-10, 1.4571 X6CrNiMoTi 17 12 2 1.4057 X20CrNi 17 2 (X17CrNi16-2), 1.4122 X39CrMo17-1, 1.4521 X2CrMoTi18-2	≤850		●	0.15...0.35	60...90 55...85
Hardened steels	-		≤40-48 HRC >48-60 HRC	●		
Special alloys	Nimonic, Inconel, Monel, Hastelloy	≤1200		●		
Cast iron	0.6010 EN-GJL-100(GG10), 0.6020 EN-GJL-200(GG20) 0.6025 EN-GJL-250(GG25), 0.6035 EN-GJL-350(GG35)		≤240 HB ≤300 HB	●○	0.30...0.60 0.30...0.60	120...200 100...160
Spheroidal graphite iron and malleable cast iron	0.7050 EN-GJS-500-7(GG50), 0.8035 EN-GJMW-350-4(GTW35) 0.7070 EN-GJS-700-2(GGG70), 0.8170 EN-GJMB-700-2(GTS70)		≤240 HB ≤300 HB	●○	0.30...0.60 0.20...0.40	100...160 80...120
Chilled cast iron	-		≤350 HB	●		
Titanium and Ti-alloys	3.7024 Ti99,5, 3.7114 TiAl5Sn2,5, 3.7124 TiCu2 3.7154 TiAl6Zr5, 3.7164 TiAl6V4, 3.7184 TiAl4Mo4Sn2,5, - TiAl8Mo1V1	≤850 850-1200		●		
Aluminium and Al-alloys	3.0255 Al99,5, 3.2315 AlMgSi1, 3.3515 AlMg1	≤400		●○	0.30...0.60	200...300
Al wrought alloys	3.0615 AlMgSiPb, 3.1325 AlCuMg1, 3.3245 AlMg3Si, 3.4365 AlZnMgCu1,5	≤450		●○	0.30...0.60	180...280
Al cast alloys ≤ 10 % Si	3.2131 G-AlSi5Cu1, 3.2153 G-AlSi7Cu3, 3.2573 G-AlSi9	≤600		●○	0.30...0.60	160...240
Al cast alloys > 10 % Si	3.2581 G-AlSi12, 3.2583 G-AlSi12Cu, - G-AlSi12CuNiMg	≤600		●○	0.30...0.60	140...200
Magnesium-alloys	MgMn2, G-MgAl8Zn1, G-MgAl6Zn3	≤450		○		
Copper, low-alloyed	2.0070 SE-Cu, 2.1020 CuSn6, 2.1096 G-CuSn5ZnPb	≤400		○		
Brass, short-chipping	2.0380 CuZn39Pb2, 2.0401 CuZn39Pb3, 2.0410 CuZn43Pb2	≤600		○	0.30...0.60	120...200
Brass, long-chipping	2.0250 CuZn20, 2.0280 CuZn33, 2.0332 CuZn37Pb0,5	≤600		○	0.20...0.40	140...200
Bronze, short-chipping	2.1090 CuSn7ZnPb, 2.1170 CuPb5Sn5, 2.1176 CuPb10Sn 2.0790 CuNi18Zn19Pb	≤600 >600-850		●○	0.30...0.60 0.20...0.40	120...200 120...200
Bronze, long-chipping	2.0916 CuAl15, 2.0960 CuAl9Mn, 2.1050 CuSn10 2.0980 CuAl11Ni, 2.1247 CuBe2	≤850 850-1000		●	0.20...0.40 0.15...0.35	140...200 140...200

GUHRING

Guhring oHG

P.O. Box 100247 · D-72423 Albstadt
Herderstr. 50-54 · D-72458 Albstadt
Telephone: +49 74 31 17-0
Fax: +49 74 31 17-2 79
www.guehring.de

Our product range:

1. Drilling Tools *in High Speed Steel and Carbide*

Twist drills
Ratio drills
Micro-precision drills
Oil feed drills
Subland drills
Centre drills
Core drills
Gun drills
Drilling systems with interchangeable inserts

2. Thread Cutting Tools *in High Speed Steel and Carbide*

Machine taps and fluteless taps
Oil feed taps and oil feed fluteless taps
Circular fluteless taps
Hand taps
Thread milling cutters
Dies

3. Milling Cutters *in High Speed Steel and Carbide*

Ratio end mills
Slot drills
End mills
Radius profile cutters
Hard profile cutters
Diesinking cutters

4. Reaming Tools *in High Speed Steel and Carbide*

NC machine chucking reamers
Machine and machine chucking reamers
Taper pin reamers
Hand reamers

5. Countersinking Tools *in High Speed Steel and Carbide*

Countersinks, counterbores and spot facers
Short counterbores, back spot facers

6. Cutting Tools *in ultra-hard materials*

Cermet and ceramic tools
PCD- and PCB-tipped tools

7. Coated Tools

A-tools, TiAlN-coated
C-tools, TiCN-coated
F-tools, FIRE-coated (allround)
S-tools, TiN-coated (allround)
M-tools, MolyGlide-coated

8. Modular Tooling Systems

Tooling system GM 300

Tool holders, clamping systems and accessories to ISO 12164, DIN 69893 and DIN 69871 for transfer lines, machining and turning centres

Flexible tooling system GE 100

a tooling system for the combined machining operations facing, chamfering, boring, centering etc.

Cartridge tooling system DP 200

with indexable inserts for roughing and finishing operations in complex workpieces

9. Special Tools

to sketch or drawing, the more complex, the better

10. Carbide

for precision cutting tools

11. Carbide Special Parts *for the forming, machining and wear protection industry*

Cold heading dies, ribbed rolls, dies, mandrels, drawing dies, gear cutters, etc.

12. Hydraulic chucks, Shrink fit chucks and systems

13. Tool Restoration Service

Re-grinding, re-coating, tool management